



Part number

CDAM 16 X



Brief description:

male insert, 16 poles + PE, screw terminal connections, 16A, 250V, 4kV, 3, silver plated, size "66.16", CLASS insert series

Product description		Approvals / Standards	
Model	male insert	Reference standard	EN 61984 (2001-11)
Version	screw terminal connections	Quality mark	 , EAC
Series	CDA	Conformity	CQC, CE
Product type	with male contacts	General ordering information	
Variant	without plate	EAN13 code	8015747013321
Family	CLASS inserts	Tariff number	85369095
Size	size "66.16"	Country of origin	Made in EU (IT)
N. of poles	16 poles + 	ETIM classification	EC000438
Technical data		Packaging Information	
Current	16 A (A.C. and D.C.)	Packaging length	140,00 mm
Voltage	250 V	Packaging height	120,00 mm
Rated impulse withstand voltage	4kV	Packaging width	260,00 mm
Pollution degree	3	Packaging weight	2,15 kg
Wire cross-section	0,25 mm ² - 2,50 mm ²	Packaging volume	4,37 dm ³
AWG size	24 - 14	Packaging description	Carton box
Operating temperature range (min, max)	-40°C ... +125°C	Packaging quantity	30 Pcs
Contact type	silver plated	Packaging EAN code	8015747013338
Mating cycles	≥ 500	Sub-packaging weight	0,36 kg
IP degree of protection	IP20 without enclosure, IP65/IP66 with enclosure	Sub-packaging description	Carton
Further technical details		Sub-packaging quantity	5 Pcs
Characteristics according to EN 61984	16A 250V 4kV 3; 16A 230/400V 4kV 2	Sub-packaging EAN barcode	8015747013345
Insulation resistance	≥ 10 GΩ		
Rated voltage according to UL/CSA	600V		
UL 94 flammability rating	V-0		
Weight	72,00 g		

Part number

CDAM 16 X



Catalogue drawings

CDAM 16

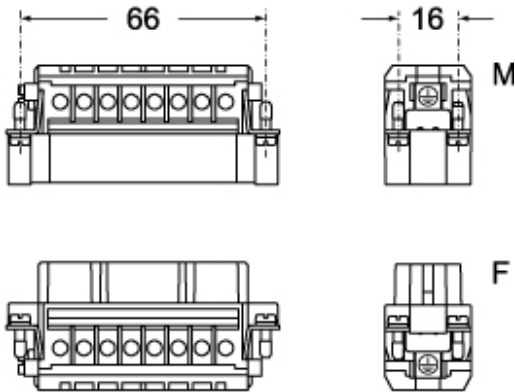

CDAF 16

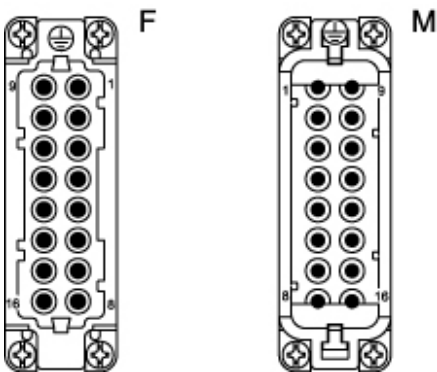

Catalogue drawings

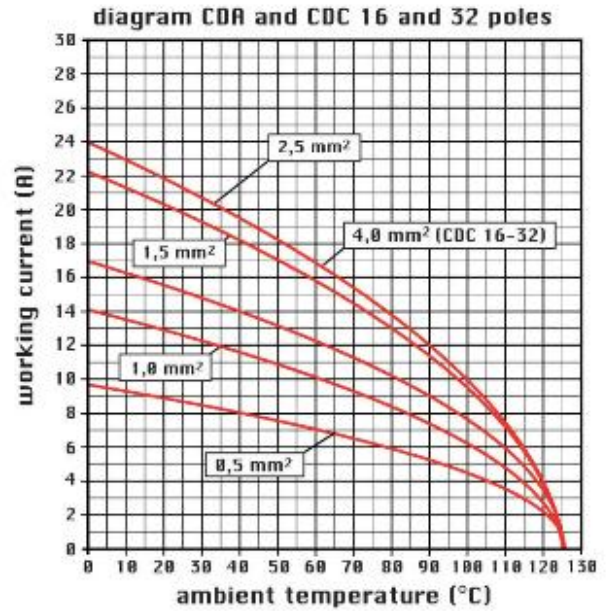

Notes

CDA ... : for non-prepared conductors



CDA ... X : for conductors with bush terminal